



2.1

Multipower DIP-SWITCH drivers - Compact case
Alimentatori multipotenza con DIP-SWITCH - Formato compatto



SMARTx 26 PLUS



SMARTx 26 PLUS BI



Rated Voltage
Tensione Nominale
220 ÷ 240 V

Frequency
Frequenza
50...60 Hz

AC Operation range
Tensione di utilizzo AC
198 ÷ 264 V

DC Operation range
Tensione di utilizzo DC
198 ÷ 280 V

Power
Potenza
5 ÷ 26 W

Typical output current ripple
 $\pm 20\%$ ⁽¹⁾

Reference Norms
Norme di riferimento
EN 50172 (VDE 0108)
EN 55015
EN 61000-3-2
EN 61000-3-3
EN 61347-1
EN 61347-2-13
EN 61547
VDE 0710-T14

Max. pcs for CB B16A
(see page info17)
50 pcs

In rush current
5A 50 μ sec

Article Articolo	Code Codice	P out W	V out DC	I out DC	V out max.	ta °C	tc °C	λ max. Power Factor	η max. Efficiency ⁽¹⁾
SMARTx 26 PLUS	122221A	16	15...45	350mA cost.	50	-25...+50	80	0,95	> 89
		22	15...45	500mA cost.					
SMARTx 26 PLUS BI	122222A	25	15...45	550mA cost.	50	-25...+50	80	0,95	> 89
		26	15...37	700mA cost.					

⁽¹⁾ Referred to $V_{in} = 230$ V, 100% load - Riferito a $V_{in} = 230$ V, carico 100%

Features

- Multipower driver supplied with dip-switch for the selection of the output current.
- IP20 independent driver, for indoor use (SMARTx 26 PLUS).
- Class I protection against electric shock for direct or indirect contact (SMARTx 26 PLUS).
- Driver for built-in use (SMARTx 26 PLUS BI).
- It can be used for lighting equipment in protection class I (SMARTx 26 PLUS BI).
- Active Power Factor Corrector.
- Current regulation $\pm 5\%$ including temperature variations.
- Input and output terminal blocks on opposite sides (wire cross-section up to 1,5 mm²/ AWG15).
- Clamping screws on primary and secondary circuits for cables with diameter: min. 2 mm - max. 9 mm (SMARTx 26 PLUS).
- Driver can be secured with slot for screws.
- Protections:
 - against overheating and short circuits;
 - against mains voltage spikes;
 - against overloads.
- Thermal protection = C.5.a.

Caratteristiche

- Alimentatore multipotenza fornito di dip-switch per la selezione della corrente in uscita.
- Alimentatore indipendente IP20, per uso interno (SMARTx 26 PLUS).
- Protetto in classe I contro le scosse elettriche per contatti diretti e indiretti (SMARTx 26 PLUS).
- Alimentatore da incorporare (SMARTx 26 PLUS BI).
- Utilizzabile per apparecchi di illuminazione in classe di protezione I (SMARTx 26 PLUS BI).
- PFC attivo.
- Corrente regolata $\pm 5\%$ incluse variazioni di temperatura.
- Morsetti di entrata e uscita contrapposti (sezione cavo fino a 1,5 mm²/ AWG15).
- Serracavo su primario e secondario per cavi di diametro: min. 2 mm - max. 9 mm (SMARTx 26 PLUS).
- Fissaggio dell'alimentatore tramite asole per viti.
- Protezioni:
 - termica e cortocircuito;
 - contro le extra-tensioni di rete;
 - contro i sovraccarichi.
- Protezione termica = C.5.a.



Direct current electronic drivers with DIP-SWITCH
Alimentatori elettronici in corrente continua con DIP-SWITCH

Made in Europe



IP 20 **SCREW FIXING** Ø54 2.13" Weight - Peso gr. 105 / 3,7 oz.
 Pcs - Pezzi 40

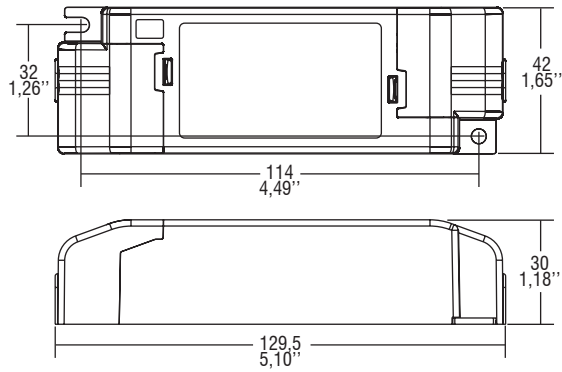

BUILT-IN **SCREW FIXING** Weight - Peso gr. 98 / 3,7 oz.
 Pcs - Pezzi -

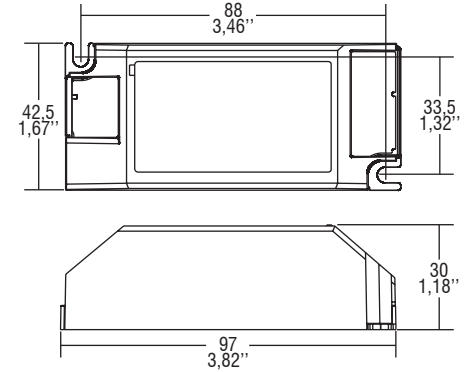

Wiring diagram - Schema di collegamento (Max. LED distance on page info8 - Massima distanza LED a pagina info8)

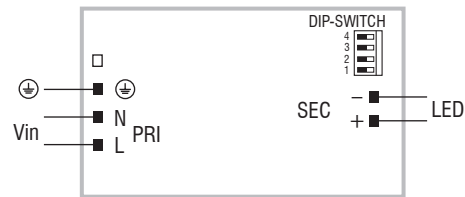

2.1

Multipower DIP-SWITCH drivers - Compact case
 Alimentatori multipotenza con DIP-SWITCH - Formato compatto